

10 BRAEBURN CT

Location 10 BRAEBURN CT

Mblu 7/ 21/ 9/ /

Acct#

Owner EKDAHL GARY I & ANNE T

Assessment \$1,272,500

PID 100374

Building Count 1

topoTopography Rolling

Utility Well, Septic

Current Value

Assessment					
Valuation Year	Building	Extra Features	Outbuildings	Land	Total
2023	\$928,100	\$11,200	\$35,800	\$297,400	\$1,272,500

Owner of Record

Owner EKDAHL GARY I & ANNE T
Address 10 BRAEBURN CT
BEDFORD, NH 03110

Sale Price \$810,000
Certificate
Book & Page 8928/2364
Sale Date 12/16/2016
Instrument 00
Qualified Q

Ownership History

Ownership History					
Owner	Sale Price	Certificate	Book & Page	Instrument	Sale Date
EKDAHL GARY I & ANNE T	\$810,000		8928/2364	00	12/16/2016
GAPPENS JERRY K JR &	\$790,000		8013/0610	00	08/22/2008
GENEST DANIEL A	\$526,900		6527/2839	00	11/26/2001
MANOR HOMES BUILDERS INC	\$80,000		6248/1266	00	06/02/2000
SKV LLC	\$0		/0		

Building Information

Building 1 : Section 1

Year Built: 2001
Living Area: 3,756

Replacement Cost: \$1,160,166

Building Percent Good: 80

Replacement Cost

Less Depreciation: \$928,100

Building Attributes

Field	Description
Style:	Colonial
Model	Residential
Grade:	Very Good
Stories:	2 Stories
Occupancy	1
Exterior Wall 1	Cedar or Redwd
Exterior Wall 2	Brick/Masonry
Roof Structure:	Gable/Hip
Roof Cover	Asph/F Gls/Cmp
Interior Wall 1	Drywall/Sheet
Interior Wall 2	
Interior Flr 1	Hardwood
Interior Flr 2	Carpet
Heat Fuel	Oil
Heat Type:	Forced Air-Duc
AC Type:	Central
Total Bedrooms:	4 Bedrooms
Total Bthrms:	4
Total Half Baths:	1
Total Xtra Fixtrs:	
Total Rooms:	9 Rooms
Bath Style:	Average
Kitchen Style:	Average
Num Kitchens	01
Cndtn	
Num Park	
Fireplaces	
Fndtn Cndtn	
Basement	

Building Photo



(https://images.vgsi.com/photos/BedfordNHPhotos/\A00\00\82\84.jpg)

Building Layout

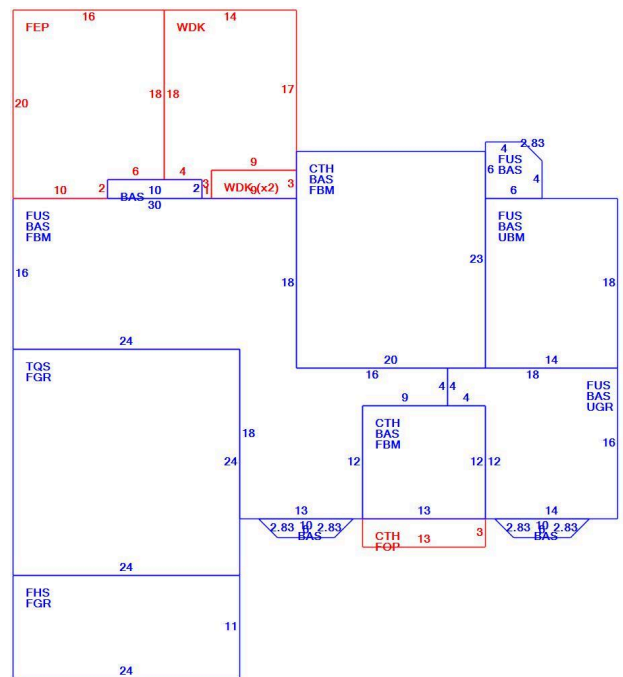

(ParcelSketch.ashx?pid=100374&bid=100418)

Building Sub-Areas (sq ft)		Legend	
Code	Description	Gross Area	Living Area
BAS	First Floor	1,930	1,930
FUS	Upper Story, Finished	1,262	1,262
TQS	Three Quarter Story	576	432
FHS	Half Story, Finished	264	132
CTH	Cathedral Ceiling	655	0
FBM	Basement, Finished	1,352	0
FEP	Porch, Enclosed, Finished	308	0
FGR	Garage, Framed	840	0
FOP	Porch, Open	39	0
UBM	Basement, Unfinished	252	0

UGR	Garage, Basement	240	0
WDK	Deck, Wood	299	0
		8,017	3,756

Extra Features

Extra Features					Legend
Code	Description	Size	Value	Assessed Value	Bldg #
FPL3	2 STORY CHIM	1.00 UNITS	\$4,200	\$4,200	1
FPO	EXTRA FPL OPEN	1.00 UNITS	\$900	\$900	1
WHL	WHIRLPOOL	1.00 UNITS	\$3,000	\$3,000	1
SNA	SAUNA	1.00 UNITS	\$3,100	\$3,100	1

Land

Land Use

Use Code 1010
 Description SINGLE FAM MDL-01
 Zone RA
 Neighborhood 80
 Alt Land Appr No
 Category

Land Line Valuation

Size (Acres) 1.9
 Frontage
 Depth
 Assessed Value \$297,400

Outbuildings

Outbuildings							Legend
Code	Description	Sub Code	Sub Description	Size	Value	Assessed Value	Bldg #
SHD2	W/LIGHTS ETC			320.00 S.F.	\$8,000	\$8,000	1
PAT1	PATIO-AVG			168.00 S.F.	\$800	\$800	1
SPL2	VINYL/PLASTIC			720.00 S.F.	\$22,500	\$22,500	1
PAT2	PATIO-GOOD			432.00 S.F.	\$4,500	\$4,500	1

Valuation History

Assessment					
Valuation Year	Building	Extra Features	Outbuildings	Land	Total
2023	\$928,100	\$11,200	\$35,800	\$297,400	\$1,272,500
2022	\$683,800	\$11,400	\$21,700	\$220,400	\$937,300
2021	\$683,800	\$11,400	\$21,700	\$220,400	\$937,300